



WB01 Thermostatic Water Bath

Please read the User Manual carefully before use, and follow all operating and safety instructions!



user manual

english

User Manual



WB01 Thermostatic Water Bath

Preface

Users should read this manual carefully, follow the instructions and procedures, and beware of all the cautions when using this instrument.

Service

In order to guarantee this equipment works safely and efficiently, it must receive regular maintenance. In case of any faults, do not try to repair it yourself. If help is needed, you can always contact your supplier or Labbox via www.labbox.com.

Please provide the customer care representative with the following information:

- Serial number
- Description of problem
- Your contact information

Warranty

This instrument is warranted to be free from defects in materials and workmanship under normal use and service, for a period of 24 months from the date of invoice. The warranty is extended only to the original purchaser. It shall not apply to any product or parts which have been damaged on account of improper installation, improper connections, misuse, accident, or abnormal conditions of operation.

For claim under the warranty please contact your supplier.

Introduction

This thermostatic bath WB01 is suitable for distillation, concentration, drying, and thermostatic heating in medical units, universities, colleges, scientific research facilities, and laboratories in industrial and mining enterprises, such as chemical, printing and dyeing, and pharmaceutical companies.

Structural Features

1. The product enclosure is crafted from high-quality steel plate and undergoes a static electric spraying process for a robust and durable surface. The inner container is meticulously finished with stainless steel stretching.
2. The liner and upper cover are constructed from high-quality stainless-steel plate, offering excellent corrosion resistance.
3. Direct water heating is achieved using a U-shaped heating pipe. This results in a quick temperature rise and minimal thermal loss.
4. The single-row digital display or intelligent temperature controller offers a simple operation and a favorable application effect.

Main Technical Parameters

Model	TWBA-001-001	TWBA-002-001	TWBA-004-001	TWBA-006-001
Voltage	200-240 V / 100-120 V			
Power (W)	400	500	1000	1500
Temperature Motion (°C)	±0.5			
Temperature Range (°C)	RT +5 – 100			
Sensibility of Temperature Control (°C)	≤±1			
Display Error (°C)	≤±2.5			
Chamber Size (mm)	150x135x150	300x150x150	325x300x150	500x300x150
Product Size (mm)	170x154x210	318x168x210	350x318x210	524x322x210
Packaging Size (mm)	240x230x280	390x240x280	420x390x280	600x390x280
Net Weight (kg)	3.3	4.5	6.0	7.5
Gross Weight (kg)	4	5	7	9

Working Conditions

1. Temperature range: 5 – 40 °C.
2. Relative humidity: <85 % RH.
3. Power: voltage 220-240 V, frequency 50-60 Hz.
4. Do not subject the equipment to strong vibration and corrosive gases.

Precautions

1. Before use, add water until it reaches 50 mm above the clapboard. Then, connect to the power supply and start heating. Avoid heating with insufficient water.
2. During use, refrain from touching the heating pipe with your hands to prevent scalding.
3. After use, promptly discharge the water, dry the equipment, and keep it clean to extend its service life.

Temperature Controller Operation

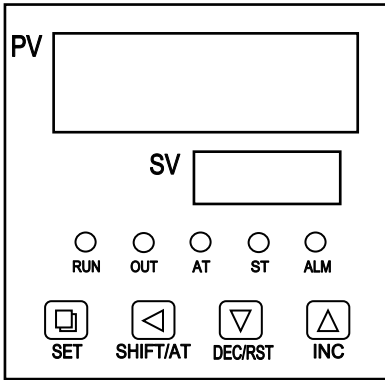

The Function of Indicator Lights:

- 1) **【RUN】** : The light is on during operation and off at the end of the run.
- 2) **【OUT】** : The light is on when there is heating output.
- 3) **【AT】** : During auto-tuning, the light flashes.
- 4) **【ST】** : When timing starts, this light is on.
- 5) **【ALM】** : The light is on during an over-temperature alarm.

1. Operation and Use

1.1. Upon powering on the controller, the upper row of the display window displays the version number and the temperature range value, while the lower row shows the maximum temperature setting value. The controller transitions to the normal view state after a 2-second initialization upon power-up.

1.2. Temperature and Time Setting:

1) Without Timing Function:

Press the “SET” button to enter the temperature setting state. The display window shows the prompt “SP” and the temperature set value. Users can edit the temperature setting value using the “SHIFT,” “DEC,” and “INC” buttons. Press the “SET” button again, and the controller will return to the normal view state, automatically saving the setting value.

2) With Timing Function:

Press the “SET” button in the non-set state; the window displays the prompt “SP” and the temperature set value. Upon re-pressing the “SET” button, the window displays the prompt “ST” and the time set value. Press the “SET” button again, and the controller will return to the normal display, automatically saving the setting value.

When the time is set to “0,” it indicates the timer is inoperative, and the controller will run continuously. If a time is set, the lower window of the controller will display the temperature setting value or the running time based on the value of “ndt” (see parameter table 2). When displaying the running time, the unit decimal point is lit. When the runtime is over, the lower window of the controller will display “End,” and the buzzer will sound for “EST” seconds (see parameter table 2). It can be muted by pressing any button. Press the “RST” button for 3 seconds at this time, and the controller will restart.

1.3. Abnormal Temperature Measurement Alarm: If the upper window of the controller displays the prompt “---,” it indicates a fault in the temperature sensor, an exceeded measuring range, or a controller malfunction. The controller will automatically cut off the heat output, and the buzzer will sound continuously. The “ALM!” indicator light will illuminate. Please carefully inspect the temperature sensor and its wiring.

1.4. In the event of an over-temperature alarm, the buzzer beeps continuously, the “ALM” warning light is illuminated, and the heat-out is cut off. For an under-temperature alarm, the buzzer beeps continuously, and the “ALM” warning light flashes. If the over-temperature alarm is triggered by a change in the temperature setting value, the “ALM” warning light is illuminated, but the buzzer does not beep.

1.5. Press any key to mute the buzzer when it sounds.

1.6. “SHIFT/AT” button: In the setting state, click the button to shift the set value. In the non-set state, press and hold the button for 6 seconds to initiate the auto-tuning program.

1.7. “DEC/RST” button: In the setting state, click the button to reduce the set value. Press and hold the button for continuous reduction. In the normal state, after the timing work is completed, press the button for 3 seconds to restart the controller.

1.8. “INC” button: In the setting state, click the button to increase the set value. Press and hold the button for continuous increase.

2. Auto-Tuning of PID

In the non-set state, press the “SHIFT/AT” button for 6 seconds. The controller will enter the pre-auto-tuning state, displaying the prompt “AT” in the upper window and “OFF” in the lower window. Users can use the “DEC” or “INC” button to choose between showing “OFF” or “ON”. When it displays the prompt “ON”, press the “SET” button, and the controller will initiate the auto-tuning program. The “AT” light flashes during auto-tuning, and after the process concludes, the light stops flashing, and the parameter value is saved automatically. During the auto-tuning process, pressing the “SHIFT/AT” button for another 6 seconds will stop the auto-tuning program. If an over-temperature alarm occurs during auto-tuning, the buzzer remains silent, the “ALM” warning light is not illuminated, and the heat-out is cut off. The “SET” button becomes invalid, and the lower window continuously displays the temperature set value.

3. Internal Parameters Settings

In the non-set state, press the “SET” button for 3 seconds. The controller will display the password prompt “Lc”. Adjust the password to the required value, then press the “SET” button again to enter the internal parameter setting state. If you press the “SET” button for another 3 seconds, it will return to the running state, and the setting value will be saved automatically.

Parameter Table 1

	Name	Function Instructions	(Setting Range) Factory Set Value
Lc	Password Key	When Lc=3, enter the next parameters.	0
ALH	Over-temperature Alarm	If “SV>(SP+ALH)”, the “ALM” light turns on, the buzzer sounds, and the heating output turns off.	(0~100.0 °C) 5.0
ALL	Under-temperature Alarm	If “SV<(SP-ALL)”, the “ALM” light flashes, and the buzzer sounds.	(0~100.0 °C) 0
P	Proportional Band	Adjustment of proportional function.	(0.1~100.0 °C) 6.0
I	Integration Time	Adjustment of integration function.	(1~2000) 200
d	Differential Time	Adjustment of differential function.	(0~1000) 200
T	Control Cycle	The temperature control cycle.	(1~60) 5
Pb	Zero Point Adjust	When the zero error is relatively larger, an update to this value may be necessary. Pb = actual value – measure value	(-50.0~50.0 °C) 0
PL	Full Point Adjust	When the full-point error is also relatively larger, an update to this value may be necessary. PK = 1000 x (actual value – measure value) / measure value.	(-999~999) 0
Addr		null	
Loc	Setting Lock	0: Enables setting temperature and time. 1: Disables setting temperature and time.	(0~1) 0

Parameter Table 2

	Name	Function Instructions	(Setting Range) Factory Set Value
Lc	Password Key	When Lc=9, enter the next parameters.	0
ndA	Temperature Alarm Mode	0: Over-temperature alarm only. 1: Over-temperature alarm and under-temperature alarms simultaneously.	(0~1) 0
ndc	Control Mode	0: PID control. 1: ON/OFF control.	(0~1) 0
dE1	Upper Deviation	Valid only for ON/OFF control.	(0~100.0 °C) 0
dE2	Lower Deviation		(0~100.0 °C) 0
ndT	Timer Mode	0: No timer function. 1: Constant temperature timing. 2: Run timing.	(0~2) 1
Hn	Timer Unit	0: Minute. 1: Hour.	(0~1) 0
SPd	Constant Temperature Deviation	When “SP>=(SV-SPd)”, the controller enters the constant-temperature state.	(0.1~100.0 °C) 0.5
SPT	Constant Temperature Buzzer Time	If in the constant-temperature state, the buzzer will beep for SPT seconds. Note: If “SPT=9999”, the buzzer will beep continuously.	(0~9999S) 0
EST	Timing Over Buzzer Time	If the timing work is over, the buzzer will beep for EST seconds. Note: If “EST=9999”, the buzzer will beep continuously.	(0~9999S) 60
EH	Whether to continue to control after timing	0: Cut off heat-out after timing. 1: Continue to control after timing.	(0~1) 0
ndo		null	
oPn		null	
nP	Maximum Power	Percentage of maximum power heating output.	(0~100%) 100
Co	Off Point	If “SV>(SP+Co)”, stop the heating output.	(0~100.0 °C) 50.0
SPL	Minimum Set Point	The minimum temperature set point.	(0~50.0 °C) 0
SPH	Maximum Set Point	The maximum temperature set point.	(SPL~100.0 °C) 100.0

Parameter Table 3

	Name	Function Instructions	(Setting Range) Factory Set Value
Lc	Password Key	When Lc=27, enter the next parameters.	0
Fc	Temperature Unit	0: Centigrade. 1: Fahrenheit.	(0~1) 0

Parameter Table 4

	Name	Function Instructions	(Setting Range) Factory Set Value
Lc	Password Key	When Lc=567, enter the next parameters.	0
rST	Reset to Default Values	0: Cancel to reset to default value. 1: Confirm to reset to default value.	(0~1) 0

4. Wiring

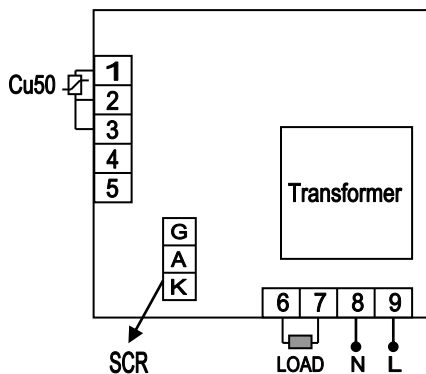

Operation

1. Place the instrument horizontally.
2. Open the cover and add pure water or distilled water to the water tank. Ensure the water level is higher than the heating pipe and temperature sensor.
3. Connect the appropriate power, switch on the power supply.
4. The upper row of the instrument displays the test temperature, and the setting temperature is shown in the lower row.
5. Briefly press the setting key to enter the setting state. Use the “SHIFT”, “PLUS”, and “MINUS” keys to adjust the temperature.
6. Press the upper key to set the time. When the upper row shows “ST” and the lower row shows “OFF”, press the upper key again, and the lower row will display the time. The “SHIFT” key is used to change the numerical unit to minutes. There are two timing modes: timing after temperature stabilization and timing after the setting is finished. When the set time is reached, the heating output stops. If you need to restart the operation, the power switch must be turned off and on again.
7. Automatic tuning function: If the test temperature fluctuates, the self-tuning function can adjust. Press the “PLUS” and “MINUS” keys until the indicator light turns on.

Fault Analysis

Failure	Possible cause	Troubleshooting
No power supply	<ol style="list-style-type: none">1. Bad contact between plug and socket.2. The fuse is burnt.	<ol style="list-style-type: none">1. Replace the plug or socket tube.2. Replace the fuse with one with the same specifications.
No temperature rise	<ol style="list-style-type: none">1. The temperature controller is broken.2. The sensor is broken.3. The set temperature is lower than the water temperature.4. The heating pipe is burnt.	<ol style="list-style-type: none">1. Replace the instrument.2. Replace the sensor.3. Reset the temperature.4. Replace the heating pipe.
Significant difference between displayed temperature and actual temperature	<ol style="list-style-type: none">1. The temperature controller is broken.2. The temperature sensor is broken.	<ol style="list-style-type: none">1. Replace the temperature controller.2. Replace the temperature sensor.

Nota importante para los aparatos electrónicos vendidos en España

Instrucciones sobre la protección del medio ambiente y la eliminación de aparatos electrónicos:



Los aparatos eléctricos y electrónicos marcados con este símbolo no pueden ser eliminados en forma de residuos urbanos.

De conformidad con la Directiva 2012/19/UE, los usuarios de la Unión Europea de aparatos eléctricos y electrónicos, tienen la posibilidad de devolver sus RAEE para su eliminación al distribuidor o fabricante del equipo después de la compra de uno nuevo. La eliminación ilegal de aparatos eléctricos y electrónicos es castigada con multa administrativa.

Remarque importante pour les appareils électroniques vendus en France

Informations sur la protection du milieu environnemental et élimination des déchets électroniques :



Les appareils électriques et électroniques portant ce symbole ne peuvent pas être jetés dans les décharges.

En réponse à la réglementation, Labbox remplit ses obligations relatives à la fin de vie des équipements électriques de laboratoire qu'il met sur le marché en finançant la filière de recyclage de ecosystem dédiée aux DEEE Pro qui les reprend gratuitement (plus d'informations sur www.ecosystem.eco).

L'élimination illégale d'appareils électriques et électroniques est punie d'amende administrative.

Nota importante per le apparecchiature elettroniche vendute in Italia

Istruzioni sulla protezione ambientale e sullo smaltimento dei dispositivi elettronici:



Le apparecchiature elettriche ed elettroniche contrassegnate con questo simbolo non possono essere smaltite come rifiuti urbani.

In conformità con la Direttiva 2012/19 / UE, gli utenti dell'Unione Europea di apparecchiature elettriche ed elettroniche hanno la possibilità di restituire i propri RAEE per lo smaltimento al distributore o al produttore di apparecchiature dopo averne acquistato uno nuovo. La rimozione illegale di apparecchiature elettriche ed elettroniche è punibile con una sanzione amministrativa.

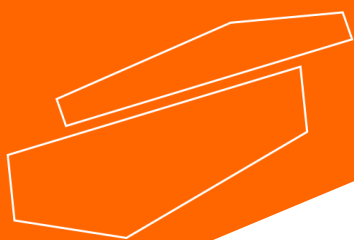

www.labbox.com