



## MM1500 Microplate Mixer

*Please read the User Manual carefully before use, and follow all operating and safety instructions!*



# user manual

english

# User Manual



## MM1500 Microplate Mixer

### Preface

Users should read this Manual carefully, follow the instructions and procedures, and beware of all the cautions when using this instrument.

### Service

If you need assistance, you can contact the distributor or Labbox through the website: [www.labbox.com](http://www.labbox.com)

Please provide the customer care representative with the following information:

- Serial number
- Description of problem
- Your contact information

### Warranty

This instrument is warranted to be free from defects in materials and workmanship under normal use and service, for a period of 24 months from the date of invoice. The warranty is extended only to the original purchaser. It shall not apply to any product or parts which have been damaged on account of improper installation, improper connections, misuse, accident or abnormal conditions of operation.

For claim under the warranty please contact your supplier.

# 1. Safety Instructions



	<b>Warning!</b> <ul style="list-style-type: none"><li>• Read the operating instructions carefully before use.</li><li>• Ensure that only trained staff works with the instrument.</li></ul>
	<b>Protective ground contact!</b> <ul style="list-style-type: none"><li>• Make sure that socket must be grounded (protective ground contact) before use.</li></ul>

Table 1

- When working wear personal safety guards to avoid the risk from:
  - Splashing and evaporation of liquids
  - Release of toxic or combustible gases
- Set up the instrument in a spacious are on a stable, clean, non-slip, dry and fireproof surface. Do not operate the instrument in explosive atmospheres, with hazardous substances or under water.
- Gradually increase the speed, reduce the speed if:
  - The medium splashes out of the vessel because of too high speed.
  - The appliance is not running smoothly.
- Be aware of hazards due to:
  - Overfilling of media
  - Unsafe container
- Check the appliance and accessories beforehand for damage each time you use them. Do not use damaged components. Safe operation is only guaranteed with the accessories described in the “Accessories” chapter. Accessories must be securely attached to the device and cannot come off by themselves.
- Always disconnect the plug before fitting accessories.
- The operating voltage required on the type plate and voltage supply network must match.
- The instrument may only be opened by experts.
- Keep away from high magnetic field.
- Observe the minimum distances between the devices, between the device and the wall and above the assembly (min. 100 mm).

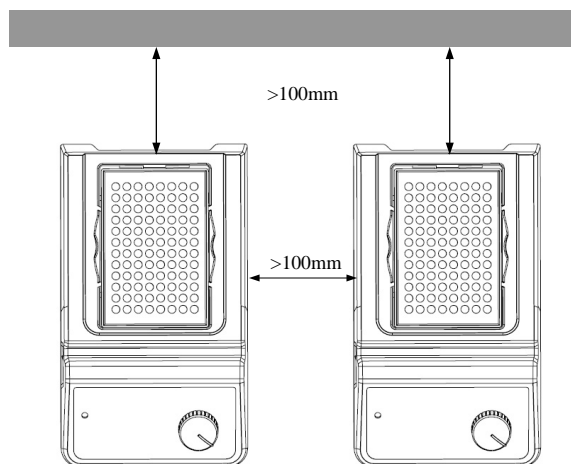

Figure 1

## 2. Proper Use

The instrument is designed for mixing liquids in schools, laboratories or factories.  
This device is not suitable for using in residential areas or other constraints mentioned in Chapter 1.

## 3. Inspection

### 3.1 Receiving Inspection

Unpack the equipment carefully and check for any damages which may have arisen during transport. Please contact manufacturer/supplier for technical support.



**Note:**  
If there is any apparent damage to the system,  
please do not plug it into the power line.

### 3.2 Listing of Items

The package includes the following items:

Items	Qty
Main unit (with adapter for 1 microplate)	1
Power cable	1
User Manual	1

Table 2

## 4. Control



Figure 2 : MM1500 series

	Items	Descriptions
MM1500	Speed control knob	The function “mixing” is switched ON or OFF via the knob. To increase the value turns the knob clockwise.
	Power Switch I/O	Switch ON or OFF the instrument.
	Power LED	When the device is switched ON, the power LED is lit.

Table 3

## 5. Trial Run

- Make sure that the required operating voltage and power supply voltage match.
- Ensure the socket must be properly grounded.
- Plug in the power adapter, ensure the power is on.
- Switch ON the instrument by pressing the power switch I/O.
- Set the rated mix speed and the device begins to work.
- Switch OFF the instrument by pressing the power switch I/O.

*If these operations above are normal, the device is ready to operate. If the operations are not normal, the device may be damaged during transportation, please contact your manufacturer/supplier for technical support.*



### Warning!

Forbid to transfer the vessel when the instrument working.

## 6. Operation

### 6.1 Load and remove microplate clamp

The microplate should be properly loaded to clamp from one side (fig.3).

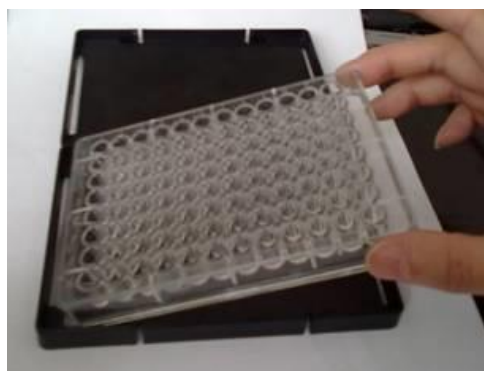

Figure 3

### 6.2 Speed range

- Microplate clamp: 0-1500rpm.
- Double microplate clamp: 0-1000rpm.

## 7. Maintenance and Cleaning

- Proper maintenance can keep instruments working properly and lengthen its lifetime.
- Do not spray cleanser into the instrument when cleaning.
- Unplug the power line when cleaning.
- Only use recommended cleansers:

Dyes	Isopropyl alcohol
Construction materials	Water containing tenside / Isopropyl alcohol
Cosmetics	Water containing tenside / Isopropyl alcohol
Foodstuffs	Water containing tenside
Fuels	Water containing tenside

Table 4

- Before using other method for cleaning or decontamination, the user must ascertain with the manufacturer that this method will not harm the instrument.
- Keep the device clean and prevent liquid splashing into the device to affect its life time.
- Wear the proper protective gloves during cleaning of the instrument.

	<b>Note:</b>
	<ul style="list-style-type: none"><li>• Electronic device cannot clean with cleanser.</li><li>• If you require maintenance service, must be cleaned the instrument in advance to avoid pollution of hazardous substances, and to send back into original packing.</li><li>• If the instrument will not use for a long time, please switch off and place in a dry, clean, room temperature and stable location.</li></ul>

## 8. Standards and Regulations

Construction in accordance with the following safety standards:  
EN 61010-1

Construction in accordance with the following EMC standards:  
EN 61326-1

Associated EU guidelines:  
EMC-guidelines: 89/336/EWG  
Machine guidelines: 73/023/EWG

## 9. Specifications

Items	Specifications
Voltage [VAC]	100~240
Frequency [Hz]	50/60
Power [W]	20
Shaking movement	Orbital
Orbital diameter [mm]	4.5
Max. shaking weight (with attachments)	0.5
Motor type	Exterior rotor Brushless motor
Motor rating input [W]	18
Motor rating output [W]	10
Permissible ON time [%]	100
Speed range [rpm]	0 – 3000
Speed display	Scale
Microplate working	Yes
Microplate amount	1
Dimensions (mm)	260×150×80
Weight [kg]	3
Permitted ambient temperature[°C]	5-40
Permitted relative humidity	80%
Protection class acc. to DIN 60529	IP21

Table 5

## 10. Accessories

Please get in touch with our company to order the following accessories available for these devices:

Accessories	References	Descriptions	Running mode
	MIXS-A31-001	Universal top plate (round). Used with tube adapters	Continuous operation
	MIXS-A11-001	Adapter for 1 microplate	Continuous operation
	MIXS-A21-001	Adapter for 2 microplates	Continuous operation
	MIXS-A41-001	Tube adapter for 48 holes test tubes, Ø 6 mm, used with MIXS-A31-001	Continuous operation
	MIXS-A51-001	Tube adapter for 18 holes test tubes, Ø 10 mm, used with MIXS-A31-001	Continuous operation
	MIXS-A61-001	Tube adapter for 12 holes test tubes, Ø 12 mm, used with MIXS-A31-001	Continuous operation
	MIXS-A71-001	Tube adapter for 8 holes test tubes, Ø 16 mm, used with MIXS-A31-001	Continuous operation
	MIXS-A81-001	Tube adapter for 8 holes test tubes, Ø 20 mm, used with MIXS-A31-001	Continuous operation

Table 6

### Changing accessories:

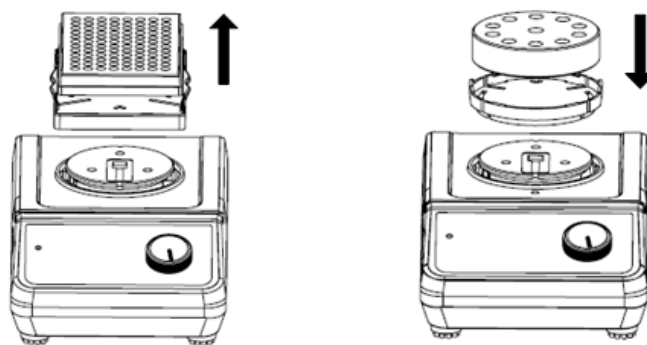

Figure 4



**Note:**

Be careful when replacing accessories, otherwise over time these accessories may be damaged.



### **Nota importante para los aparatos electrónicos vendidos en España**

Instrucciones sobre la protección del medio ambiente y la eliminación de aparatos electrónicos:



Los aparatos eléctricos y electrónicos marcados con este símbolo no pueden ser eliminados en forma de residuos urbanos.

De conformidad con la Directiva 2012/19/UE, los usuarios de la Unión Europea de aparatos eléctricos y electrónicos, tienen la posibilidad de devolver sus RAEE para su eliminación al distribuidor o fabricante del equipo después de la compra de uno nuevo. La eliminación ilegal de aparatos eléctricos y electrónicos es castigada con multa administrativa.

### **Remarque importante pour les appareils électroniques vendus en France**

Informations sur la protection du milieu environnemental et élimination des déchets électroniques :



Les appareils électriques et électroniques portant ce symbole ne peuvent pas être jetés dans les décharges.

En réponse à la réglementation, Labbox remplit ses obligations relatives à la fin de vie des équipements électriques de laboratoire qu'il met sur le marché en finançant la filière de recyclage de ecosystem dédiée aux DEEE Pro qui les reprend gratuitement (plus d'informations sur [www.ecosystem.eco](http://www.ecosystem.eco)).

L'élimination illégale d'appareils électriques et électroniques est punie d'amende administrative.

### **Nota importante per le apparecchiature elettroniche vendute in Italia**

Istruzioni sulla protezione ambientale e sullo smaltimento dei dispositivi elettronici:



Le apparecchiature elettriche ed elettroniche contrassegnate con questo simbolo non possono essere smaltite come rifiuti urbani.

In conformità con la Direttiva 2012/19 / UE, gli utenti dell'Unione Europea di apparecchiature elettriche ed elettroniche hanno la possibilità di restituire i propri RAEE per lo smaltimento al distributore o al produttore di apparecchiature dopo averne acquistato uno nuovo. La rimozione illegale di apparecchiature elettriche ed elettroniche è punibile con una sanzione amministrativa.

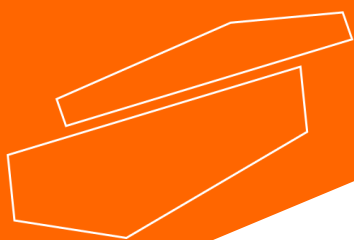

[www.labbox.com](http://www.labbox.com)